

**PLAN**

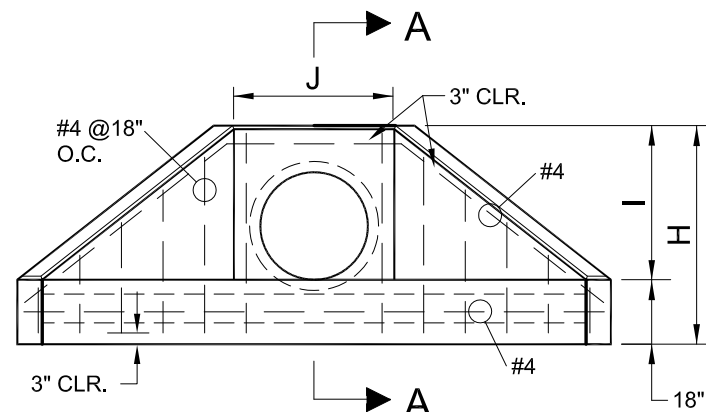

**ELEVATION**

REFER TO TDEC MANUAL, BMP OP-1, TABLE 1 FOR RIPRAP OUTLET PROTECTION SPECIFICATIONS. RIPRAP MAY BE REQUIRED TO BE WIRE ENCLOSED. SEE SECTION 02370 FOR ALTERNATIVE RIPRAP OPTION.

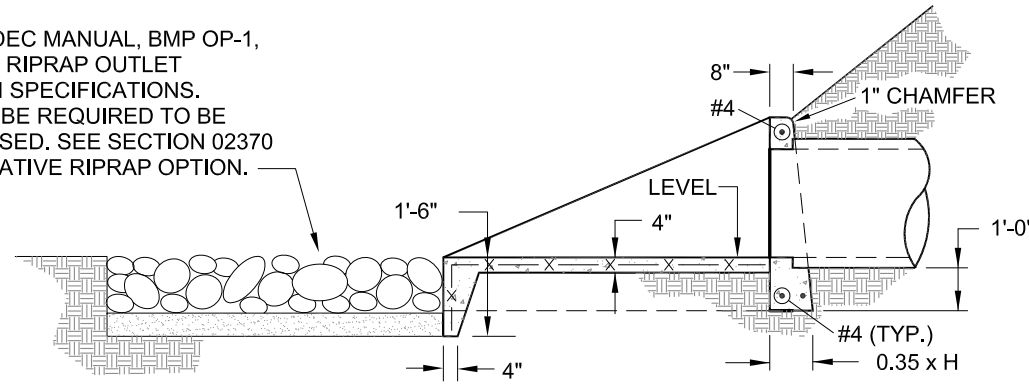

**SECTION A-A**

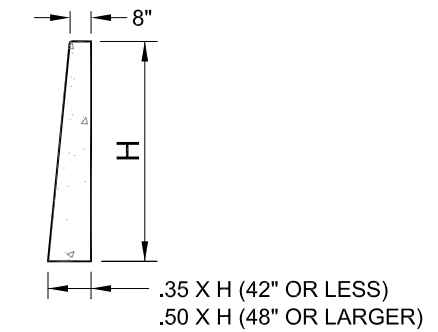

**SECTION B-B**

**TABLE OF DIMENSIONS AND DIAMETERS**

DIM	15"	18"	21"	24"	30"	36"	42"	48"	54"	60"	66"	72"
A	5'-3"	5'-11"	7'-1"	7'-1"	8'-4"	9'-7"	10'-10"	12'-0"	13'-4"	14'-9"	16'-0"	17'-3"
B	4'-11"	5'-6"	6'-8"	6'-8"	7'-11"	9'-2"	10'-5"	11'-8"	12'-11"	14'-3"	15'-6"	16'-9"
C	6'-3"	7'-1"	8'-10"	8'-10"	10'-8"	12'-6"	14'-4"	16'-2"	18'-0"	20'-0"	21'-10"	23'-8"
D	7'-11"	8'-10"	10'-7"	10'-7"	12'-5"	14'-3"	16'-1"	17'-11"	19'-9"	21'-9"	23'-7"	25'-5"
E	3'-10"	4'-5"	5'-5"	5'-5"	6'-6"	7'-7"	8'-8"	9'-9"	10'-10"	12'-0"	13'-1"	14'-2"
F	1'-9"	2'-1"	2'-7"	2'-7"	3'-2"	3'-9"	4'-4"	4'-10"	5'-6"	6'-2"	6'-9"	7'-4"
G	2'-8"	2'-11"	3'-5"	3'-5"	4'-0"	4'-11"	5'-2"	5'-10"	6'-4"	7'-0"	7'-7"	8'-2"
H	3'-5"	3'-8"	3'-11"	4'-2"	4'-8"	5'-2"	5'-8"	6'-2"	6'-8"	7'-2"	7'-8"	8'-2"
I	1'-11"	2'-2"	2'-8"	2'-8"	3'-3"	3'-9"	4'-4"	4'-10"	5'-5"	6'-0"	6'-6"	7'-1"
J	1'-7"	1'-11"	2'-5"	2'-5"	3'-0"	3'-7"	4'-2"	4'-9"	5'-4"	6'-0"	6'-7"	7'-2"

NOTE: PRECAST CONCRETE TO BE CLASS "AS", 4000 PSI, 28 DAY STRENGTH, MINIMUM.

**TYPE "D" HEADWALL WITH WINGWALLS**

NOT TO SCALE

CITY OF LAKELAND  
ENGINEERING DIVISION

**TYPE "D" HEADWALL**

REV.	DESCRIPTION	DATE
1	ORIGINAL ISSUE	8/2008